

■ TLB BI-DIRECTIONAL LINEAR DIFFUSER ■

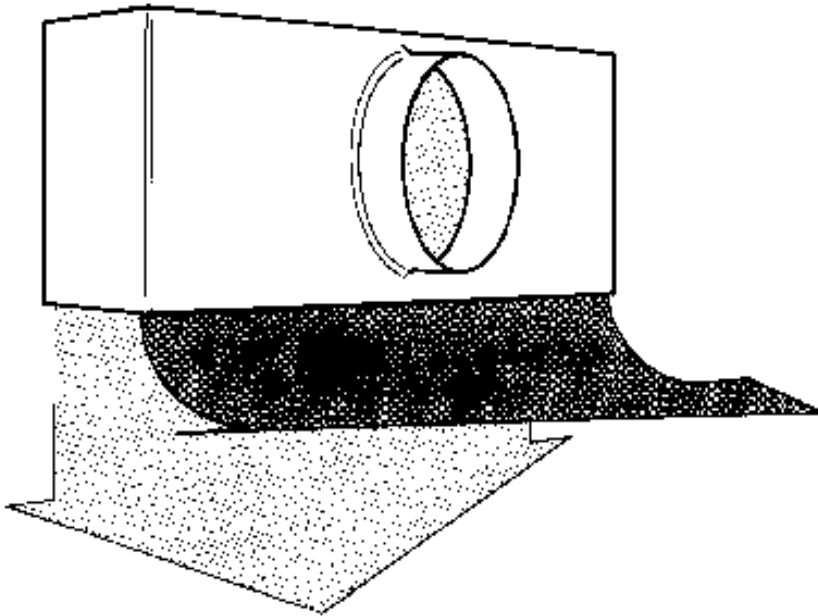

■ FEATURES ■

- Self-Contained Thermally Powered
- Automatically Changes from Horizontal to Vertical Air Flow
- Saves Energy on Existing and New Systems
- Adjustable from Face of Diffuser
- Independent Cooling and Heating Volume and Throw

The Thermal-Logic bi-directional linear slot diffuser (TLB Series) is designed for use where horizontal air flow is required for cooling and vertical air flow is required for heating.

The Thermal-Logic diffuser was designed to reduce energy cost and increase the comfort level in a room.

Typically, warm air in the room will rise to the ceiling and stratify. The temperature difference between the ceiling and the floor in a room can be as much as 20 degrees.

The stratified heat that rises to the ceiling is largely wasted as people do not occupy that space. When in the heating mode, the Thermal-Logic diffuser, directs warm air vertically to the floor. The primary air stream discharge from the unit induces the warm stratified air at the ceiling into the stream and sends it to the lower occupied portion of the room. The net effect is that of more uniform comfort, greater consistency in room temperatures between the ceiling and the floor, and energy savings by utilizing the stratified heat to help warm the occupied portions of the room.

When the Thermal-Logic diffuser is positioned in front of an exterior wall, warm air discharging from the unit blankets the exterior wall with warm air. This will reduce uncomfortable cold drafts associated with the exterior walls and windows.

The Thermal-Logic diffuser is totally self-powered by a thermal element. The thermal element has a long proven history of reliability. It functions as a motor to power the unit. The principal of operation is a basic and simple one. That of thermal expansion when a substance changes state, in this case from a liquid to a solid. The energy provided by the element is coupled to an operating mechanism to change the air flow pattern from horizontal to vertical.

In the cooling mode, when the discharge temperature is less than 70 degrees F. the air flow pattern is horizontal. In the heating mode, when the discharge temperature is greater than 78 degrees F. the air flow pattern is vertical.

The heating CFM required is usually 50% of the cooling CFM required. The Thermal-Logic diffuser has independent heating and cooling volume controls. These controls are accessible and adjustable from the face of the unit. The volume and throw in the heating and cooling modes can then be adjusted independently.